

Isuzu Diesel Engines

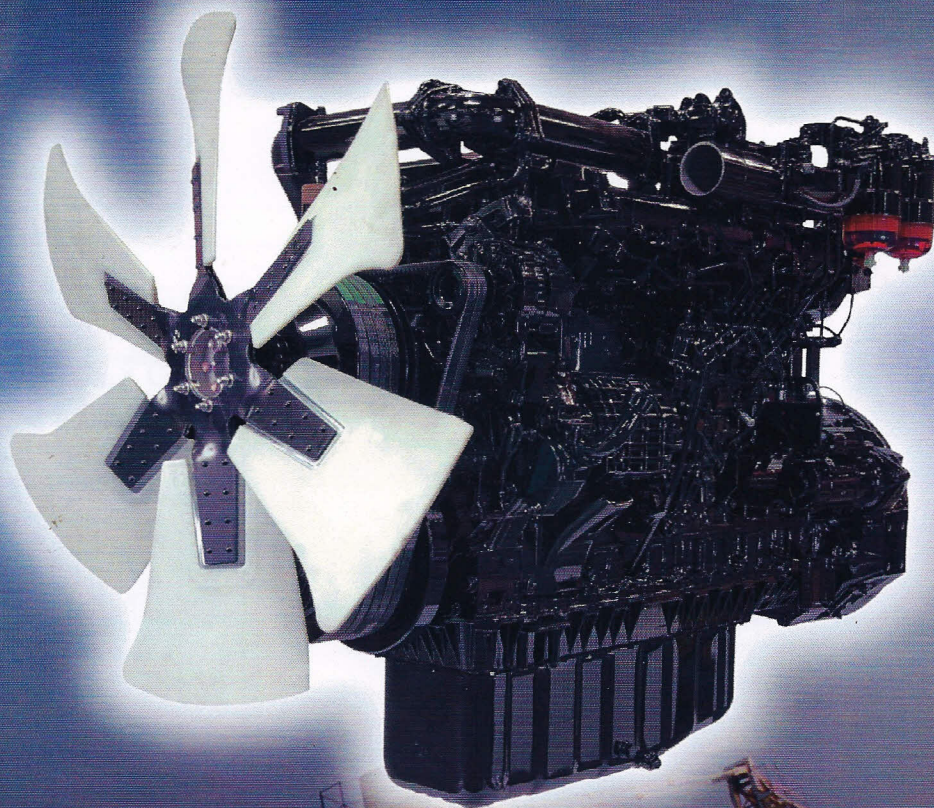

6WG1X

Generator: 532 HP @ 1800 RPM

Industrial Drive: 549 HP @ 1800 RPM

Standard features:

- U.S. EPA Tier 3
- Displacement: 15.7 L
- Turbo charged & charge air cooled
- Peak torque: 1709 LB/FT @ 1500 RPM
- Fuel consumption: .342 LB/HP-HR
- Flywheel housing: SAE 1
- Electric & self-priming fuel lift pump
- 12V electrics
- Glow plug starting aid
- High angularity oil pan
- 500-hour service intervals
- 5-year / 5,000-hour warranty

The power behind it all.

ISUZU

DIESEL

6WG1X Industrial Performance Curves:

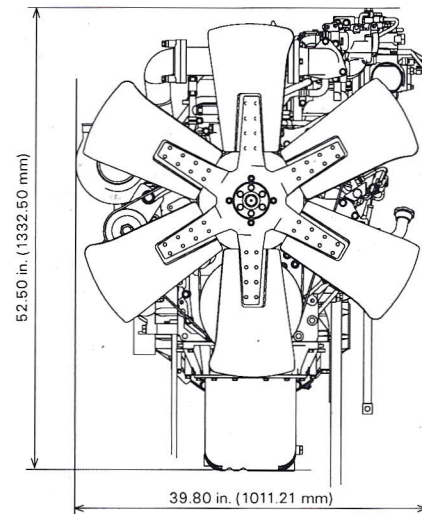
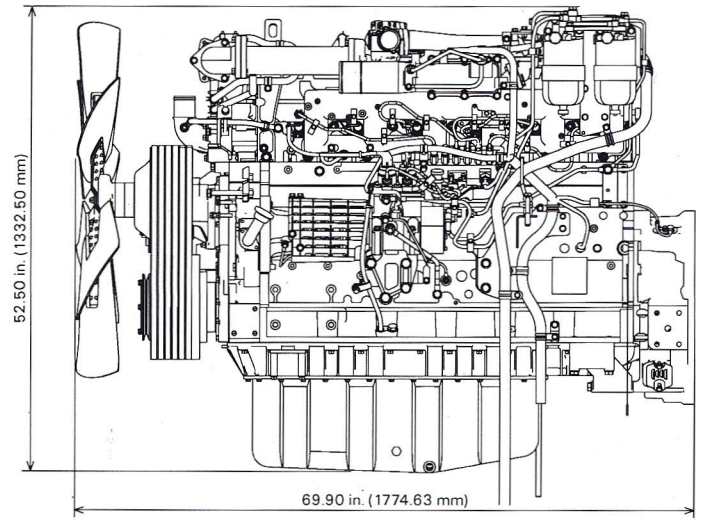
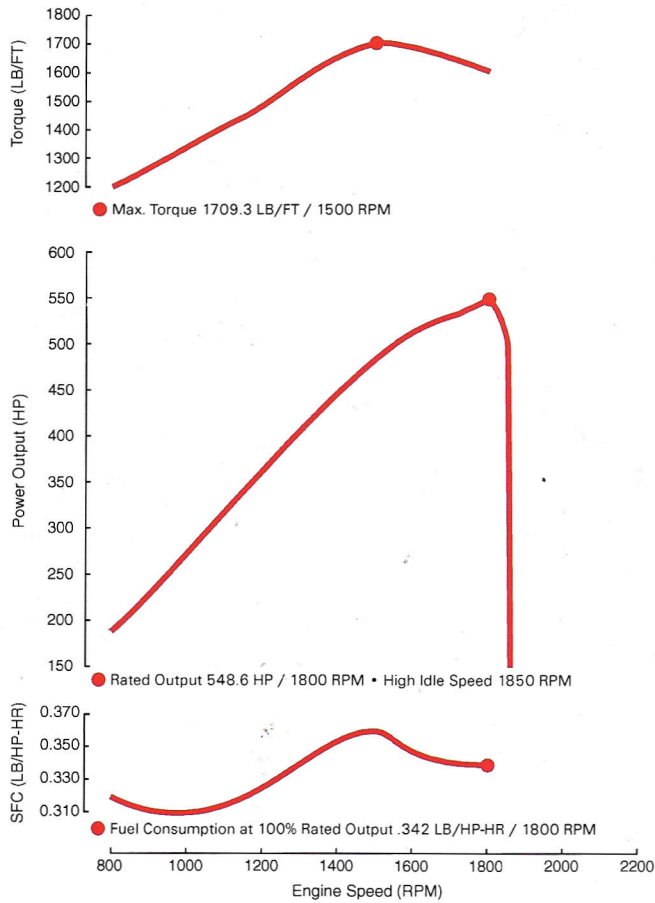

6WG1X Genset Performance Curves:

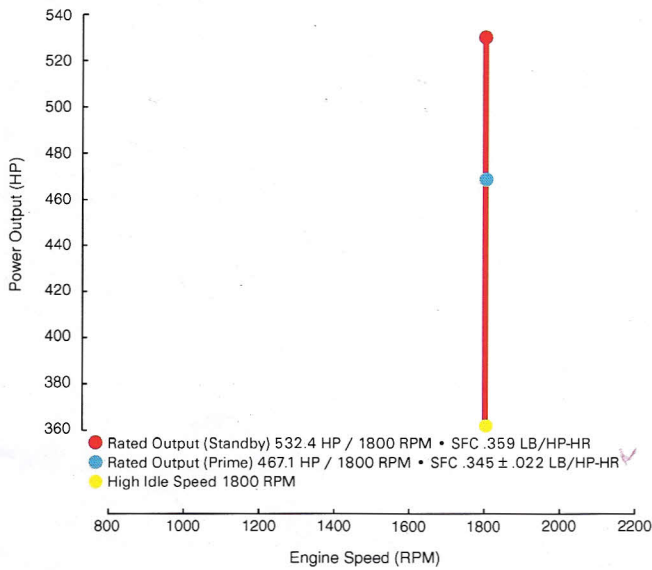

Available options:

- Cooling system
- Air cleaner
- Exhaust system
- Front and rear mounts
- Skid base
- Instrument panel & extension harness
- Custom power unit

Horsepower comparison:

Engine Model	Cylinders	Displacement (L)	HP Range
6HK1X	6	7.8	225-300
6UZ1X	6	9.8	275-375

For additional information, please contact your local distributor or visit www.isuzuengines.com

Isuzu Motors America, Inc.

46401 Commerce Center Drive
 Plymouth, Michigan 48170
 Phone: 734.582.9470
 Fax: 734.455.7581